

# Nomenclature Corps / Body Parts list / Stückliste Körper / Nomenclatura Corpo / Nomenclatura Cuerpo / Specification huvuddel

Rep. Item Pos.	Qté Qty Mge	Code Part N° Teile-Nr	Désignation	Description	Bezeichnung
1	1	OD5412	Manchon	Sleeve	Hülse
2	1	OD2662	Joint torique 15,54x2,62 (jeu x 5)	15.54x2.62 O-ring (set x 5)	O-Ring 15,54x2,62 (5-er Satz)
3	1	OD5413	Came	Cam	Nocke
4	4	OD6754	Vis M4x12 (jeu x 10)	M4x12 screw (set x 10)	Schraube M4x12 (10-er Satz)
5	2	OD5414	Vis PTWN 1412 K30/16 (jeu x 10)	1412 K30/16 PTWN screw (set x 10)	Schraube PTWN 1412 K30/16 (10-er Satz)
6	1	OD6620	Minirupteur avec galet	Micro-switch with wafer	Mikroschalter mit Rolle
7	1	OD5415	Support micro rupteur	Micro-switch support	Halterung Mikroschalter
8	1	OD7860	Goupille G06 5x25 (jeu x 10)	G06 5x25 pin (set x 10)	Stift G06 5x25 (10-er Satz)
9	1	OD5997	Arbre K19 équipé	K19 shaft assembly	Welle K19 ausgestattet
10	1	OD5419	Défecteur	Deflector	Abweiser
11	1	OKI998	Joint à lèvres 28x40x7 (jeu x 5)	28x40x7 lip seal (set x 5)	Simmering 28x40x7 (5-er Satz)
12	1	OD0520	Rondelle de 4 (jeu x 10)	4 washer (set x 10)	4-er U-Scheibe (10-er Satz)
13	1	OD3567	Cosse laiton terre (jeu x 5)	Brass earth cable terminal (set x 5)	Erdungsanschluss Bronze (5-er Satz)
14	1	voir S3	Broche	Spindle	Stift
15	1	OD0396	Goupille G05 5x20 (jeu x 10)	G05 5x20 pin (set x 10)	Stift G05 5x20 (10-er Satz)
16	1	OKQ479	Goupille G01 3x16 (jeu x 10)	G01 3x16 pin (set x 10)	Stift G01 3x16 (10-er Satz)
17	1	OD5427	Bouton	Button	Taster
18	1	OD5428	Guide	Guide	Führung
19	1	OD5429	Corps	Body	Gehäuseoberteil
20	1	OD6439	Support PSA complet	Complete PSA support	Halterung PSA komplett
21	1	OD7492	Bouton ég	Button assembly	Taster ausgestattet
102	1	Voir S30	Axe rotatif	Pin	Achse
103	2	OD7859	Circlips 8E ( j x 10 )	Circlip 8E ( set x 10 )	Sicherungsring 8E ( 10-er Satz )
104	2	OD7857	Coussinet ( j x 10 )	Bearing ( set x 10 )	Rollager (10-er Satz )
105	2	OD7858	Circlips 6E ( j x 10 )	Circlip 6E ( set x 10 )	Sicherungsring 6E ( 10-er Satz )
106	1	OD3043	Bouchon ( j x 10 )	Cap ( set x 10 )	Stopfen (10er- Satz )
S1		OD5430	Manchon + guide complet	Complete sleeve + guide	Hülse + Führung komplett
S2		OD5431	Support microrupteur équipé	Micro-switch support assembly	Halterung Mikroschalter ausgestattet
S3		OD5432	Broche équipée	Spindle assembly	Stift ausgestattet
S4		OD5433	Corps équipé	Body assembly	Gehäuseoberteil ausgestattet
S30		OD7856	Axe rotatif ég.	Assembly pin	Achse ausgestattet

N° N. Ref	Qtà Cad Kvant	Cod Código Kod	Designazione	Descripción	Beskrivning
1	1	OD5412	Giunto	Manguito	Spak
2	1	OD2662	Guarnizione torica 15,54x2,62 (set x 5)	Junta tórica 15,54x2,62 (juego x 5)	O-ring 15,54x2,62 (sats x 5)
3	1	OD5413	Camma	Leva	Kam
4	4	OD6754	Vite M4x12 (set x 10)	Tornillo M4x12 (juego x 10)	Skruv M4x12 (sats x 10)
5	2	OD5414	Vite PTWN 1412 K30/16 (set x 10)	Tornillo PTWN 1412 K30/16 (juego x 10)	Skruv PTWN 1412 K30/16 (sats x 10)
6	1	OD6620	Microinterruttore con rotella	Microinterruptor de rodillo	Minikontaktor med brytkontakt
7	1	OD5415	Supporto microinterruttore	Soporte microinterruptor	Stöd minikontaktor
8	1	OD7860	Spina G06 5x25 (set x 10)	Pasador G06 5x25 (juego x 10)	Stift G06 5x25 (sats x 10)
9	1	OD5997	Albero K19 in dotazione	Árbol K19 equipado	Utrustad axel I K19
10	1	OD5419	Deflettore	Deflector	Detektor
11	1	OKI998	Guarnizione a labbro 28x40x7 (set x 5)	Junta de labios 28x40x7 (juego x 5)	Skårfog 28x40x7 (sats x 5)
12	1	OD0520	Rondella da 4 (Set x 10)	Arandela de 4 (juego x 10)	Bricka, 4 (sats x 10)
13	1	OD3567	Capocorda ottone terra (set x 5)	Terminal latón tierra (juego x 5)	Uttag, mässing, jord (sats x 5)
14	1	voir S3	Mandrino	Pasador	Spindel
15	1	OD0396	Spina G05 5x20 (set x 10)	Pasador G05 5x20 (juego x 10)	Stift G05 5x20 (sats x 10)
16	1	OKQ479	Spina G01 3x16 (set x 10)	Pasador G01 3x16 (juego x 10)	Stift G01 3x16 (sats x 10)
17	1	OD5427	Pulsante	Botón	Knapp
18	1	OD5428	Guida	Guía	Ledskada
19	1	OD5429	Corpo	Cuerpo	Huvuddel
20	1	OD6439	Supporto PSA completo	Soporte PSA completo	Komplett stöd, PSA
21	1	OD7492	Pulsante in dotazione	Botón equipado	Utrustad Knapp
102	1	Voir S30	Asse	Eje	Axel
103	2	OD7859	Anello 8E ( set x 10 )	Circlip 8E ( juego x 10 )	Fjaderring 8E ( sats x 10 )
104	2	OD7857	Cuscinetto ( set x 10 )	Rollager ( juego x 10 )	Rullager ( sats x 10 )
105	2	OD7858	Anello 6E ( set x 10 )	Circlip 6E ( juego x 10 )	Fjaderring 6E ( Sats x 10 )
106	1	OD3043	Tappo ( set x 10 )	Tapon ( juego x 10 )	Propp ( Sats x 10 )
S1		OD5430	Giunto + guida completa	Manguito + guía completa	Spak + komplett ledskena
S2		OD5431	Supporto microinterruttore in dotazione	Soporte microinterruptor equipado	Stöd, utrustad minikontaktor
S3		OD5432	Manicotto in dotazione	Pasador equipado	Utrustad spindel
S4		OD5433	Corpo in dotazione	Cuerpo equipado	Utrustad huvuddel
S30		OD7856	Asse in dotazione	Eje equipado	Utrustad axel

**Vue éclatée Corps / Body exploded view / Explosionszeichnung - Körper /  
 Esploso Corpo / Despiece Cuerpo / Sprängskiss huvuddel \_\_\_\_\_**

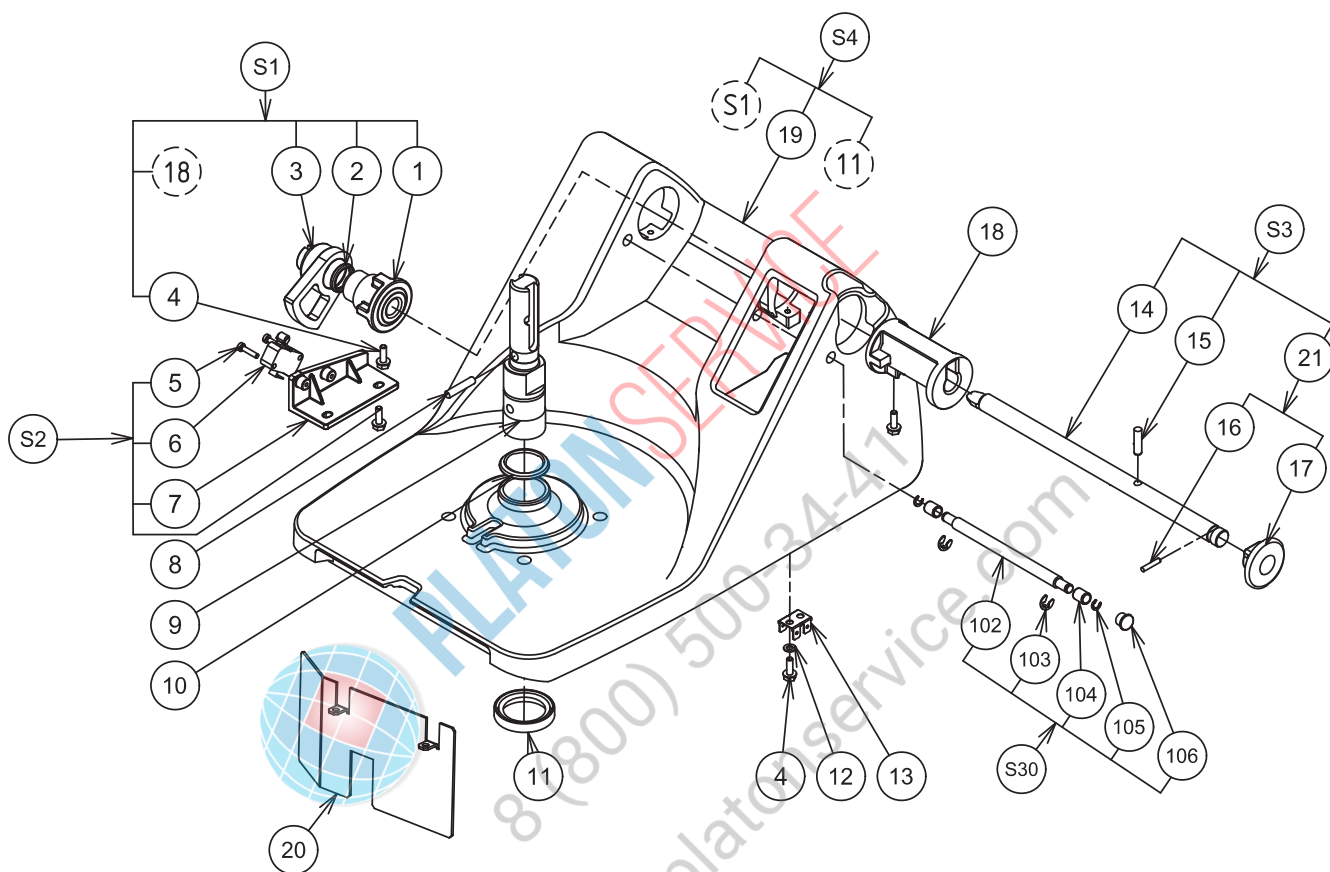

# Nomenclature Moteur / Motor Parts list / Stückliste Motor / Nomenclatura Motore / Nomenclatura Motor / Spezifikation Motor

Rep. Item Pos.	Qté Qty Mge	Code Part N° Teile-Nr	Désignation	Description	Bezeichnung
8	1	0D7860	Goupille G06 5x25 (jeu x 10)	G06 5x25 pin (set x 10)	Stift G06 5x25 (10-er Satz)
9	1	voir S7	Arbre k19	K19 shaft	Welle K19
10	1	0D5419	Défecteur	Deflector	Abweiser
11	1	0K1998	Joint à lèvres 28x40x7 (jeu x 5)	G02 6x24 pin (set x 10)	Stift G02 5x24 (10-er Satz)
24	1	0D0571	Goupille G02 6x24 (jeu x 10)	28x40x7 lip seal (set x 5)	Simmering 28x40x7 (5-er Satz)
25	4	0D1017	Vis TRL M6x16 (jeu x 10)	M6x16 TRL screw (set x 10)	Flache Halbrundschraube M6x16 (10-er Satz)
30	4	0D5144	Joint torique (jeux5)	O-ring (set x 5)	O-ring (10-er Satz)
S5		0D5585	Mot. 1V. Mono 230/240-50Hz-0.75Kw K45	Single ph mot1V. 230/240-50Hz-0.75Kw K45	Wechselstr.mot.1V 230/240-50Hz-0.75Kw K45
		0D6011	Mot. 1V Mono 220/60	Single ph mono 1V 220/60	Wechselstr.mot.1V 220/60
		0D5586	Mot. 2V. Tri 380/440-50/60Hz-0.65/0.9Kw K45	Three ph mot.2V 380/440-50/60Hz-0.65/0.9Kw K45	Drehstr.mot.2V 380/440-50/60Hz-0.65/0.9Kw K45
		0D5797	Mot. 2V. Tri 380/440-50/60Hz-0.75/1Kw K55	Three ph mot.2V 380/440-50/60Hz-0.75/1Kw K55	Drehstr.mot.2V 380/440-50/60Hz-0.75/1Kw K55
		0D5798	Mot. 2V. Tri 380/440-50/60Hz-0.9/1.2Kw K70	Three ph mot.2V 380/440-50/60Hz-0.9/1.2Kw K70	Drehstr.mot.2V 380/440-50/60Hz-0.9/1.2Kw K70
		0D5841	Mot. 2V. Tri 208/240-60Hz-0.65/0.9Kw K45	Three ph mot.2V 208/240-60Hz-0.65/0.9Kw K45	Drehstr.mot.2V 208/240-60Hz-0.65/0.9Kw K45
		0D5842	Mot. 2V. Tri 208/240-60Hz-0.75/1Kw K55	Three ph mot.2V 208/240-60Hz-0.75/1Kw K55	Drehstr.mot.2V 208/240-60Hz-0.75/1Kw K55
		0D5843	Mot. 2V. Tri 208/240-60Hz-0.9/1.2Kw K70	Three ph mot.2V 208/240-60Hz-0.9/1.2Kw K70	Drehstr.mot.2V 208/240-60Hz-0.9/1.2Kw K70
		0D5844	Mot. 2V. Tri 200 50-60Hz-0.75/1Kw K55	Three ph mot.2V 200 50-60Hz-0.75/1Kw K55	Drehstr.mot.2V 200 50-60Hz-0.75/1Kw K55
		0D5845	Mot. VV. Tri 230/400-50Hz-1Kw K45	Three ph mot.VV 230/400-50Hz-1Kw K45	Drehstr.mot.VV 230/400-50Hz-1Kw K45
		0D5846	Mot. VV. Tri 230/400-50Hz-1.3Kw K55	Three ph mot.VV 230/400-50Hz-1.3Kw K55	Drehstr.mot.VV 230/400-50Hz-1.3Kw K55
		0D5847	Mot. VV. Tri 230/400-50Hz-1.5Kw K70	Three ph mot.VV 230/400-50Hz-1.5Kw K70	Drehstr.mot.VV 230/400-50Hz-1.5Kw K70
S7	1	0D5997	Arbre équipé	Shaft assembly	Welle komplett

N° N. Ref	Qtà Cad Kvant	Cod Código Kod	Designazione	Descripción	Beskrivning
8	1	0D7860	Spina G06 5x25 (set x 10)	Pasador G06 5x25 (juego x 10)	Stift G06 5x25 (sats x 10)
9	1	voir S7	Albero K19	Árbol K19	Axel k19
10	1	0D5419	Deflettore	Deflector	Detektor
11	1	0K1998	Guarnizione a labbro 28x40x7 (set x 5)	Junta de labios 28x40x7 (juego x 5)	Skärfog 28x40x7 (sats x 5)
24	1	0D0571	Spina G02 6x24 (set x 10)	Pasador G02 6x24 (juego x 10)	Stift G02 6x24 (sats x 10)
25	4	0D1017	Vite TRL M6x16 (set x 10)	Tornillo TRL M6x16 (juego x 10)	Skruv TRL M6x16 (sats x 10)
30	4	0D5144	Guarnizione torica (set x 5)	Junta tórica 15,54x2,62 (juego x 5)	O-ring 15,54x2,62 (sats x 5)
S5		0D5585	Mot. mono 1V 230/240-50Hz-0.75Kw K45	Mot. mono 1V 230/240-50Hz-0.75Kw K45	Mot. enfasis 1V 230/240-50Hz-0.75Kw K45
		0D6011	Mot. mono 1V 220/60	Mot. mono 1v 220/60	Mot. enfasing 1v 220/60
		0D5586	Mot. tri 2V 380/440-50/60Hz-0.65/0.9Kw K45	Mot. tri 2V 380/440-50/60Hz-0.65/0.9Kw K45	Mot. tre 2V 380/440-50/60Hz-0.65/0.9Kw K45
		0D5797	Mot. tri 2V 380/440-50/60Hz-0.75/1Kw K55	Mot. tri 2V 380/440-50/60Hz-0.75/1Kw K55	Mot. tre 2V 380/440-50/60Hz-0.75/1Kw K55
		0D5798	Mot. tri 2V 380/440-50/60Hz-0.9/1.2Kw K70	Mot. tri 2V 380/440-50/60Hz-0.9/1.2Kw K70	Mot. tre 2V 380/440-50/60Hz-0.9/1.2Kw K70
		0D5841	Mot. tri 2V 208/240-60Hz-0.65/0.9Kw K45	Mot. tri 2V 208/240-60Hz-0.65/0.9Kw K45	Mot. tre 2V 208/240-60Hz-0.65/0.9Kw K45
		0D5842	Mot. tri 2V 208/240-60Hz-0.75/1Kw K55	Mot. tri 2V 208/240-60Hz-0.75/1Kw K55	Mot. tre 2V 208/240-60Hz-0.75/1Kw K55
		0D5843	Mot. tri 2V 208/240-60Hz-0.9/1.2Kw K70	Mot. tri 2V 208/240-60Hz-0.9/1.2Kw K70	Mot. tre 2V 208/240-60Hz-0.9/1.2Kw K70
		0D5844	Mot. tri 2V 200 50-60Hz-0.75/1Kw K55	Mot. tri 2V 200 50-60Hz-0.75/1Kw K55	Mot. tre 2V 200 50-60Hz-0.75/1Kw K55
		0D5845	Mot. tri VV 230/400-50Hz-1Kw K45	Mot. tri VV 230/400-50Hz-1Kw K45	Mot. tre VV 230/400-50Hz-1Kw K45
		0D5846	Mot. tri VV 230/400-50Hz-1.3Kw K55	Mot. tri VV 230/400-50Hz-1.3Kw K55	Mot. tre VV 230/400-50Hz-1.3Kw K55
		0D5847	Mot. tri VV 230/400-50Hz-1.5Kw K70	Mot. tri VV 230/400-50Hz-1.5Kw K70	Mot. tre VV 230/400-50Hz-1.5Kw K70
S7	1	0D5997	Gruppo albero	Arbol equipado	Utrustad axel

# Nomenclature Caisson / Casing Parts list / Stückliste Gehäuse / Nomenclatura Cassone / Nomenclatura Carcasa / Spezifikation behällare

Rep. Item Pos.	Qté Qty Mge	Code Part N° Teile-Nr	Désignation	Description	Bezeichnung
26	1	0D5592	Passe-fil 9x14x3 (jeu x 10)	9x14x3 grommet (set x 10)	Införingskydd 9x14x3 (sats x 10)
27	1	voir S6	Caisson droit	Straight casing	Höger behällare
28	4	0D6754	Vis M 4x12 (jeu x 10)	M 4x12 screw (set x 10)	Skruv M 4x12 (sats x 10)
29	4	0D7136	Patin équipé (jeu x 6)	Pad assembly (set x 6)	Skenfot komplett (sats x 6)
		0D6782	Ecrou HU M6 (jeu x 10)	Nut HU M6 (set x 10)	Mutter M6 gezahnt (10-er Satz)
		0D0615	Vis TC M6x16 (jeu x 10)	M6x16 TC screw (set x 10)	Schraube M6x16 (10-er Satz)
S6		0D5435	Caisson droit équipé	Straight casing assembly	Utrustad höger behällare

N° N. Ref	Qtà Cad Kvant	Cod Código Kod	Designazione	Description	Bezeichnung
26	1	0D5592	Occhiello 9x14x3 (set x 10)	Pasahilos 9x14x3 (juego x 10)	Occhiello 9x14x3 (set x 10)
27	1	voir S6	Cassone destro	Carcasa derecha	Cassone destro
28	4	0D6754	Vite M 4x12 (set x 10)	Tornillo M4x12 (juego x 10)	Vite M 4x12 (set x 10)
29	4	0D7136	Base (Set x 6)	Patin (juego x 6)	Base (Set x 6)
		0D6782	Dado HU M6 base dentata (jeu x 10)	Tuerca HU M6 base dentada (juego x 10)	Mutter HU M6 med räfflad fläns (sats x 10)
		0D0615	Vite TC M6x16 (set x 10)	Tornillo TC M6x16 (juego x 10)	Skruv TC M6x16 (sats x 10)
S6		0D5435	Cassone destro in dotazione	Carcasa derecha equipada	Cassone destro in dotazione

**Vue éclatée Moteur+Caisson / Motor + Casing exploded view / Explosionszeichnung Motor + Gehäuse / Esploso Motore+Cassone / Despiece Motor+Carcasa / Sprängskiss motor+behållare**

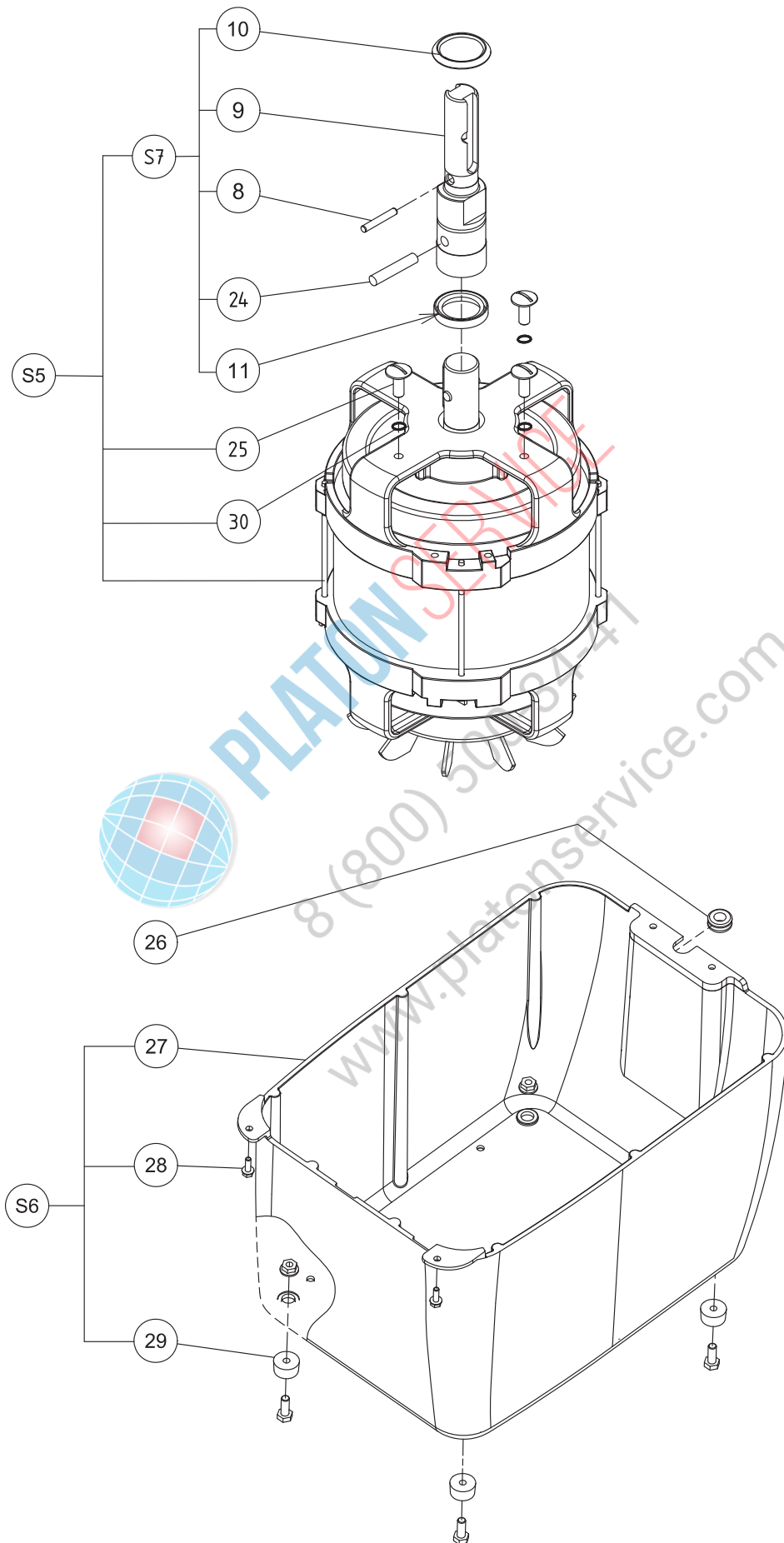



# Nomenclature Couvercle + Cuve / Lid + Bowl Parts list / Stückliste Kessel + Deckel / Nomenclatura Coperchio + Vasca / Nomenclatura Tapa + Cuba / Specifikation lock + skål

Rep. Item Pos.	Qté Qty Mge	Code Part N° Teile-Nr	Désignation	Description	Bezeichnung
32	1	voir S8	Poignée de racleur	Scraper handle	Griff Schaber
34	1	voir S8	Racleur de cuve K45	K45 bowl scraper	Schaber Kessel K45
		voir S8	Racleur de cuve K55/K70	K55/K70 bowl scraper	Schaber Kessel K55/K70
35	1	OD5439	Poignée bride de couvercle	Lid clamp handle	Griff Stift Deckel
39	2	OD5442	Cache vis 6p creux (jeu x 10)	6p concave screw cover (set x 10)	Blende Innensechskantschrauben (10-er Satz)
40	2	OD2108	Vis TCHC M5x10 (jeu x 15)	M5x10 TCHC screw (set x15)	Zylinderkopfschraube mit Innensechskant M5x10 (15-er Satz)
41	1	voir S11	Cuve	Bowl	Kessel
42	1	653579	Rotor lisse 4,5 litres	4.5-litre smooth rotor	Rotor glatt 4,5 Liter
	1	653580	Rotor micro dentés 4,5 litres	4.5-litre micro-toothed rotor	Rotor mikroverzahnt 4,5 Liter
	1	653581	Rotor lisse 5 litres	5-litre smooth rotor	Rotor glatt 5 Liter
	1	653582	Rotor micro dentés 5 litres	5-litre micro-toothed rotor	Rotor mikroverzahnt 5 Liter
	1	653583	Rotor lisse 7 litres	7-litre smooth rotor	Rotor glatt 7 Liter
	1	653584	Rotor micro dentés 7 litres	7-litre micro-toothed rotor	Rotor mikroverzahnt 7 Liter
43	1	OD5490	Joint de couvercle	Lid seal	Dichtung Abdeckung
44	1	OD5491	Couvercle 4,5/5,5 litres	5-litre lid	Deckel 5 Liter
	1	OD5492	Couvercle 7 litres	7-litre lid	Deckel 7 Liter
S8		OD5493	Racleur cuve couvercle complet K45	K45 complete bowl lid scraper	Schaber Kessel Deckel komplett K45
		OD5494	Racleur cuve couvercle complet K55/K70	K55/K70 complete bowl lid scraper	Schaber Kessel Deckel komplett K55/K70
S10		OD5496	Poignée de cuve équipée	Bowl handle assembly	Kesselgriff ausgestattet
S11		653589	Cuve 4,5 litres complète	Complete 4.5-litre bowl	Kessel 4,5 Liter komplett
		653590	Cuve 5 litres complète	Complete 5-litre bowl	Kessel 5 Liter komplett
		653593	Cuve 7 litres complète	Complete 7-litre bowl	Kessel 7 Liter komplett
S12		OD5500	Couvercle 4,5/5 litres complet	Complete 4.5/5-litre lid	Deckel 4,5/5 Liter komplett
		OD5511	Couvercle 7 litres complet	Complete 7-litre lid	Deckel 7 Liter komplett

N° N. Ref	Qtà Cad Kvant	Cod Código Kod	Designazione	Descripción	Beskrivning
32	1	voir S8	Maniglia raschietto	Asa de rasqueta	Handtag, skärare
34	1	voir S8	Raschietto vasca K45	Rasqueta de cuba K45	Skärare, skål K45
		voir S8	Raschietto vasca K55/K70	Rasqueta de cuba K55/K70	Skärare, skål K55/K70
35	1	OD5439	Impugnatura flangia coperchio	Asa brida de tapa	Handtagsfäste, lock
39	2	OD5442	Coprivite 6p con incavo (set x 10)	Cubretornillos 6p huecos (juego x 10)	Skydd, skruv med ihåligt huvud 6st. (sats x 10)
40	2	OD2108	Vite TCHC M5x12 (set x15)	Tornillo TCHC M5x10 (juego x15)	Skruv TCHC M5x10 (sats x 15)
41	1	voir S11	Vasca	Cuba	Skål
42	1	653579	Rotore liscio 4,5 litri	Rotor liso 4,5 litros	Slät rotor 4,5 liter
	1	653580	Rotore microdentato 4,5 litri	Rotor microdentadas 4,5 litros	Mikrotandad rotor 4,5 liter
	1	653581	Rotore liscio 5 litri	Rotor liso 5 litros	Slät rotor 5 liter
	1	653582	Rotore microdentato 5 litri	Rotor microdentadas 5 litros	Mikrotandad rotor 5 liter
	1	653583	Rotore liscio 7 litri	Rotor liso 7 litros	Slät rotor 7 liter
	1	653584	Rotore microdentato 7 litri	Rotor microdentadas 7 litros	Mikrotandad rotor 7 liter
43	1	OD5490	Guarnizione coperchio	Junta de tapa	Tätning, lock
44	1	OD5491	Coperchio 4,5/5,5 litri	Tapa 5 litros	Lock 5 liter
	1	OD5492	Coperchio 7 litri	Tapa 7 litros	Lock 7 liter
S8		OD5493	Raschietto vasca coperchio completo K45	Rasqueta cuba tapa completa K45	Komplett skärare, skål, lock K45
		OD5494	Raschietto vasca coperchio completo K55/K70	Rasqueta cuba tapa completa K55/K70	Komplett skärare, skål, lock K55/K70
S10		OD5496	Impugnatura vasca in dotazione	Asa de cuba equipada	Utrustat skålhandtag
S11		653589	Vasca 4,5 litri completa	Cuba 4,5 litros completa	Komplett skål 4,5 liter
		653590	Vasca 5 litri completa	Cuba 5 litros completa	Komplett skål 5 liter
		653593	Vasca 7 litri completa	Cuba 7 litros completa	Komplett skål 7 liter
S12		OD5500	Coperchio 4,5/5 litri completo	Tapa 4,5/5 litros completa	Komplett lock 4,5/5 liter
		OD5511	Coperchio 7 litri completo	Tapa 7 litros completa	Komplett lock 7 liter

**Vue éclatée Couvercle + Cuve / Lid + Bowl exploded view / Explosionszeichnung Kessel + Deckel / Esploso Coperchio + Vasca / Despiece Tapa + Cuba / Sprängskiss lock+skål**

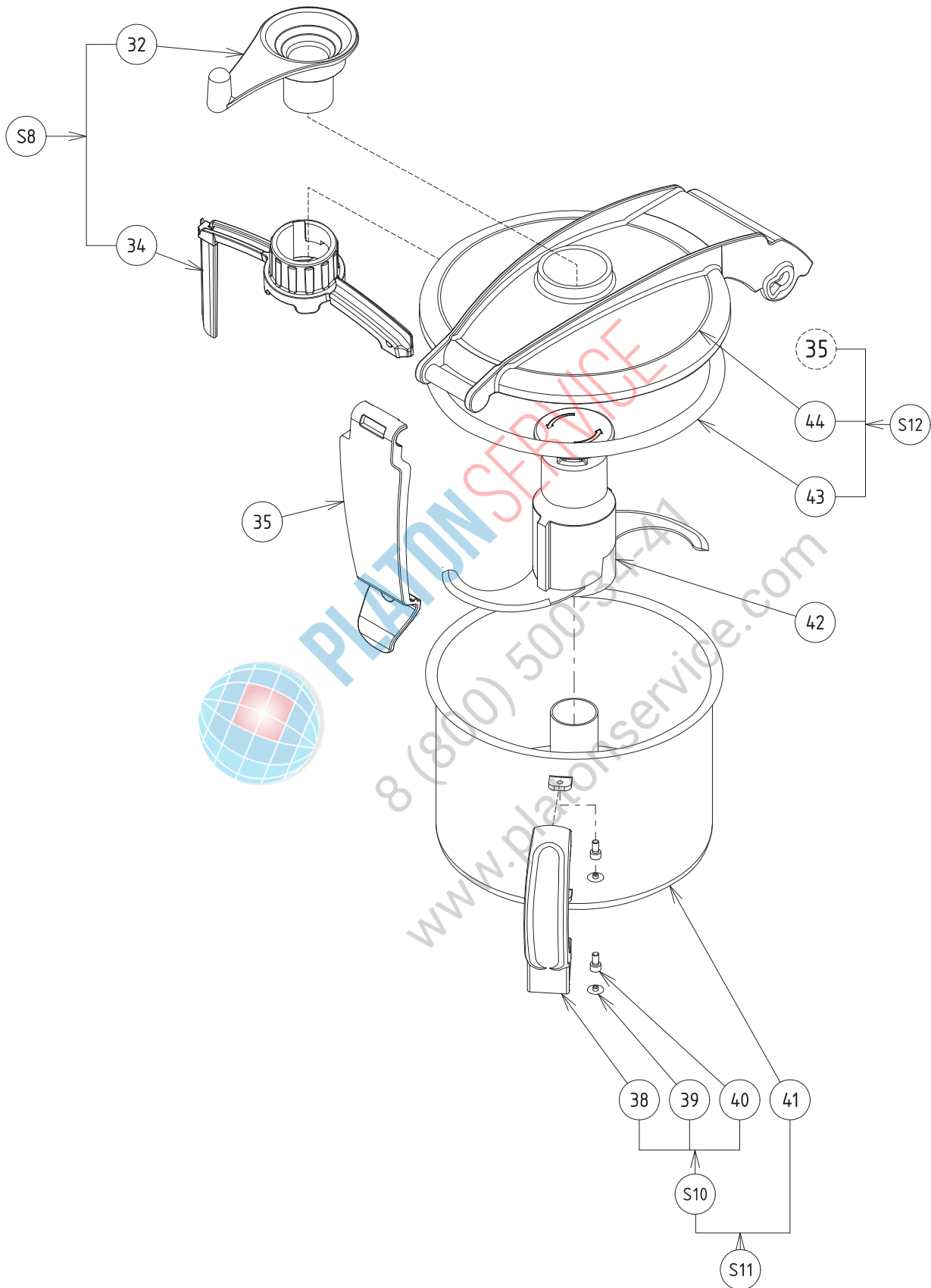

# Nomenclature commande platine vitesse monophasé / Parts list 1-speed single phase Control circuit board / Nomenclatura comando piastra 1 velocità monofase / Nomenclatura mando platina 1 velocidad monofásica / Spezifikation kontroll - platin 1 hastighet enfasisig

Rep. Item Pos.	Qté Qty Mge	Code Part N° Teile-Nr	Désignation	Description	Bezeichnung
19	1	0D5429	Corps	Body	Gehäuseoberteil
48	1	0D7086	Plaque tableau de bord K45 1v	K45 1-sp control panel plate	Platte Bedienerfeld K45 1 GS
	1	0D5513	Plaque tableau de bord K55 1v	K55 1-sp control panel plate	Platte Bedienerfeld K55 1 GS
	1	0D5514	Plaque tableau de bord K70 1v	K70 1-sp control panel plate	Platte Bedienerfeld K70 1 GS
49	1	0D5515	Support carte commande	Control card support	Halterung Steuerkarte
50	1	0D6245	Carte commande P/M/A	Power/On/Off control card	Steuerkarte P/E/A
51	2	0D2918	Vis PTWN 1442 K30/8 (jeu x 10)	1442 K30/8 PTWN screw (set x 10)	Schraube PTWN 1442 K30/8 (jeu x 10)
53	2	0D5517	Support détecteur	Detector support	Sensorhalterung
54	3	0D6754	Vis M 4x12 (jeu x 10)	M 4x12 screw (set x 10)	Schraube M4x12 (10-er Satz)
55	2	0D6626	Détecteur proximité	Proximity detector	Näherungsschalter
56	2	0D0551	Vis taptite M6x12 (jeu x 10)	M6x12 Taptite screw (set x 10)	Taptite Schraube M6x12 (10-er Satz)
57	1	0D3590	Ecrou HU M8 cranté (jeu x 10)	HU M8 ring nut (set x 10)	Sechskantmutter M8 mit Verzahnung (10er-Satz)
58	1	0H1044	Condensateur permanent 20 mf	20 mf running capacitor	Dauerkondensator 20 mf
59	1	0D6438	Lyre	Spring clip	Federklammer
60	5	0D2848	Entretoise fixation c.i. (jeu x 6)	Printed circuit fixing spacer (set x 6)	Abstandshalter Befestigung Platine (6-er Satz)
61	1	0D5518	Support composant c.i.	Printed circuit component support	Halterung Bauteil Platine
62	1	0KQ429	Carte de puissance mono	Single phase power card	Leistungskarte Wechselstrom
63	1	0D5135	Barrette à bornes (jeu x 5)	Terminal bar (set x 5)	Klemmenreihe (5-er Satz)
64	1	0KQ209	Klixon 4 CR2-731	4 CR2-731 Klixon device	Klixon 4 CR2-731
65	3	0D3429	Vis tole M4x8 (jeu x 10)	M4x8 tapping screw (set x 10)	Blechschräube M4x8 (10-er Satz)
66	1	0D5545	Cordon d'alimentation mono équipé	Single phase power supply lead assembly	Stromkabel Wechselstrom ausgestattet
67	1	0D6040	Collier CV8 jeu x 10)	CV8 tie (set x 10)	Schelle CV8 (10-er Satz)
68	1	0KQ203	Condensateur démarrage 115 mf	115 mf start capacitor	Startkondensator 115 mf
S14		0D5519	Carte commande complète K 45 1v	Complete K 45 1-sp control card	Steuerkarte komplett K 45 1 GS
		0D5520	Carte commande complète K 55 1v	Complete K 55 1-sp control card	Steuerkarte komplett K 55 1 GS
		0D5521	Carte commande complète K 70 1v	Complete K 70 1-sp control card	Steuerkarte komplett K 70 1 GS
S15		0D5542	Support PSA complet (porte clips)	Complete PSA support (clip holder)	Halterung PSA komplett (cliphalter)
S16		0D5523	Platine complète 1 v mono K45/55/70	Complete 1v single phase K45/55/70 circuit board	Platine komplett 1 GS Wechselstrom K45/55/70

N° N. Ref	Qtà Cad Kvant	Cod Código Kod	Designazione	Descripción	Beskrivning
19	1	0D5429	Corpo	Cuerpo	Huvuddel
48	1	0D7086	Piastra pannello comandi K45 1v	Placa panel de mando K45 1v	Platta kontrollpanel K45 1v
	1	0D5513	Piastra pannello comandi K55 1v	Placa panel de mando K55 1v	Platta kontrollpanel K55 1v
	1	0D5514	Piastra pannello comandi K70 1v	Placa panel de mando K70 1v	Platta kontrollpanel K70 1v
49	1	0D5515	Supporto scheda di comando	Soporte tarjeta de mando	Stöd drivkort
50	1	0D6245	Scheda di comando P/M/A	Tarjeta mando P/M/A	Drivkort P/M/A
51	2	0D2918	Vite PTWN 1442 K30/8 (set x 10)	Tornillo PTWN 1442 K30/8 (juego x 10)	Skruv PTWN 1442 K30/8 (sats x 10)
53	2	0D5517	Supporto rilevatore	Soporte detector	Stöd detektor
54	3	0D6754	Vite M 4x12 (set x 10)	Tornillo M4x12 (juego x 10)	Skruv M 4x12 (sats x 10)
55	2	0D6626	Rilevatore di prossimità	Detector proximidad	Lägesdetektor
56	2	0D0551	Vite taptite M6x12 (set x 10)	Tornillo taptite M6x12 (juego x10)	Skruv M6x12 (sats x 10)
57	1	0D3590	Dado HU M8 dentato (set x 10)	Tuerca HU M8 microdentada (juego x 10)	Tandmutter HU M8 (sats x 10)
58	1	0H1044	Condensatore permanente 20 mf	Condensador permanente 20 mf	Permanent kondensator 20 mf
59	1	0D6438	Lira	Soporte lira	Lyra
60	5	0D2848	Distanziatore di fissaggio c.i. (set x 6)	Distanciador fijación c.i. (juego x 6)	Distansstycke montering t.k. (sats x 6)
61	1	0D5518	Supporto componente c.i.	Soporte componente c.i.	Stöd komponent t.k.
62	1	0KQ429	Scheda di potenza mono	Tarjeta de potencia mono	Effektort, mono
63	1	0D5135	Ponticello per morsetti (set x 5)	Puente placa de bornes (juego x 5)	Uttagsplint (sats x 5)
64	1	0KQ209	Klixon 4 CR2-731	Klixon 4 CR2-731	Klixon 4 CR2-731
65	3	0D3429	Vite lamiera M4x8 (set x 10)	Tornillo chapa M4x8 (juego x 10)	Gångpressande skruv M4x8 (sats x 10)
66	1	0D5545	Cavo di alimentazione mono in dotazione	Cable de alimentación mono equipado	Utrustad elsladd, mono
67	1	0D6040	Fascetta CV8 (set x 10)	Abrazadera CV8 (juego x 10)	Klämma CV8 sats x 10)
68	1	0KQ203	Condensatore di avviamento 115 mf	Condensador arranque 115 mf	Startkondensator 115 mf
S14		0D5519	Scheda di comando completa K 45 1v	Tarjeta mando completa K 45 1v	Komplett drivkort K 45 1v
		0D5520	Scheda di comando completa K 55 1v	Tarjeta mando completa K 55 1v	Komplett drivkort K 55 1v
		0D5521	Scheda di comando completa K 70 1v	Tarjeta mando completa K 70 1v	Komplett drivkort K 70 1v
S15		0D5542	Supporto PSA completo (portaclip)	Soporte PSA completo (portaclips)	Komplett stöd, PSA (clipshållare)
S16		0D5523	Piastra completa 1 v mono K45/55/70	Platina completa 1 v mono K45/55/70	Komplett platin, 1 v mono K45/55/70

**Vue éclatée commande platine vitesse monophasé / 1-speed single phase control circuit board exploded view / Explosionszeichnung Steuerung Platine 1 Geschwindigkeit Wechselstrom / Esploso comando piastra 1 velocità monofase / Despiece mando platina 1 velocidad monofásica / Sprängskiss kontroll- platin 1 hastighet, enfasig**

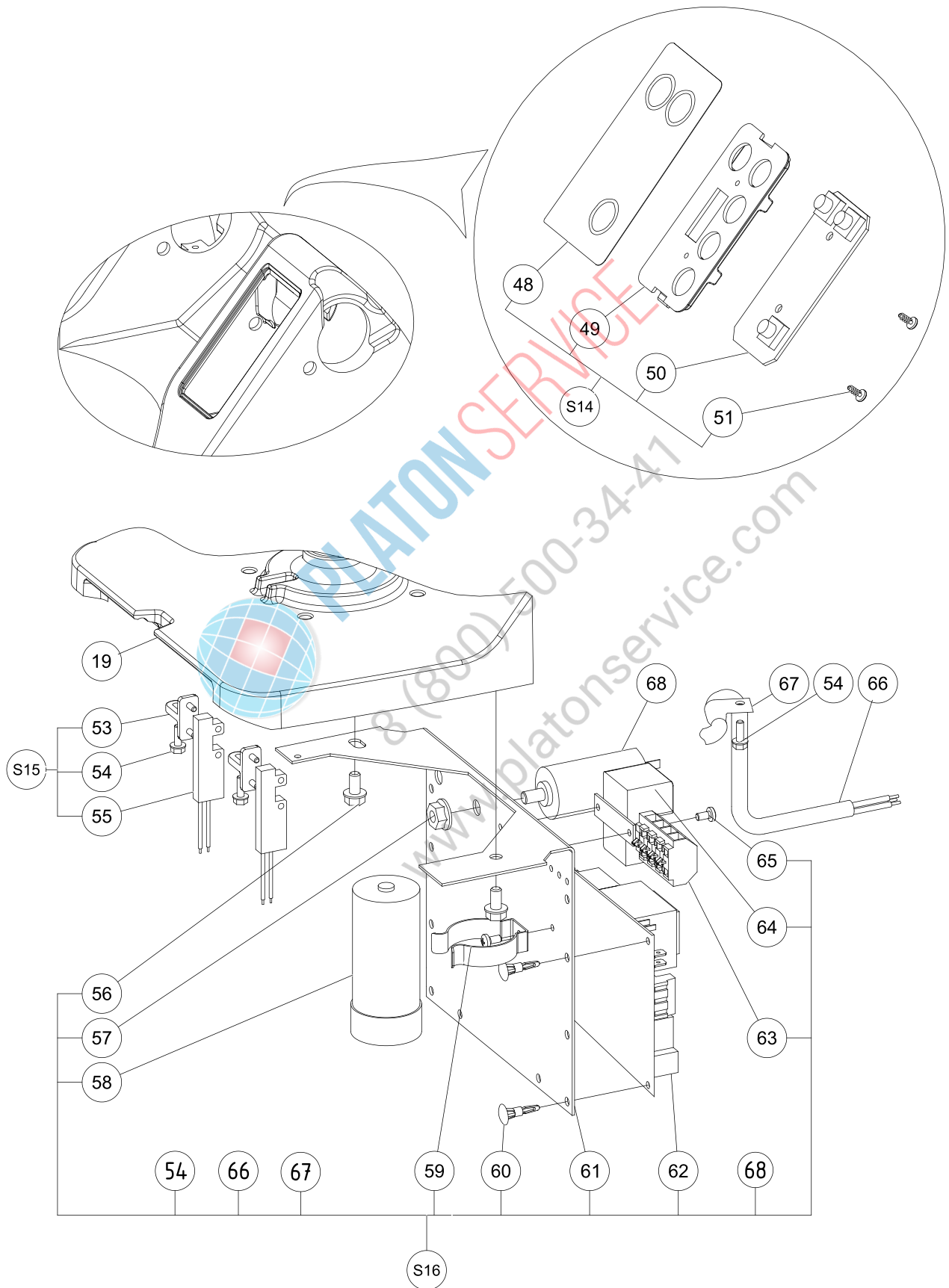



# Nomenclature platine 2 vitesses triphasé / Parts list 2-speed three-phase circuit board / Stückliste Platine 2 Geschwindigkeiten Drehstrom / Nomenclatura piastra 2 velocità trifase / Nomenclatura platina 2 velocidades trifásica / Specifikation platin 2 hastigheter, trefasig

Rep. Item	Qté Qty	Code Part N° Teile-Nr	Désignation	Description	Bezeichnung
19	1	0D5429	Corps	Body	Gehäuseoberteil
49	1	0D5515	Support carte commande	Control card support	Halterung Steuerkarte
51	2	0D2918	Vis PTWN 1442 K30/8 (jeu x 10)	1442 K30/8 PTWN screw (set x 10)	Schraube PTWN 1442 K30/8 (jeu x 10)
53	2	0D5517	Support détecteur	Detector support	Sensorhalterung
54	3	0D6754	Vis M4x12 (jeu x 10)	M4x12 screw (set x 10)	Schraube M4x12 (10-er Satz)
55	2	0D6626	Détecteur de proximité	Proximity detector	Näherungsschalter
79	1	0D7087	Plaque tableau de bord K45 2 V	K45 2-sp. control panel plate	Platte Bedienerfeld K45 2 GS
	1	0D7089	Plaque tableau de bord K55 2 V	K55 2-sp. control panel plate	Platte Bedienerfeld K55 2 GS
	1	0D7091	Plaque tableau de bord K70 2 V	K70 2-sp. control panel plate	Platte Bedienerfeld K70 2 GS
80	1	0D5600	Carte de commande 2 vitesses	2-speed control card	Steuerkarte 2 Geschwindigkeiten
81	1	0H1034	Condensateur de freinage 200 mf	200 mf brake capacitor	Bremskondensator 200 mf
82	1	0D3429	Vis tole M4x8 (jeu x 10)	M4x8 tapping screw (set x 10)	Blehschraube M4x8 (10-er Satz)
83	1	0D6438	Lyre	Spring clip	Federklammer
84	2	0D6708	Vis taptite M6x16 (jeu x 10)	M6x16 Taptite screw (set x 10)	Taptite Schraube M6x16 (10-er Satz)
85	6	0D2848	Entretoise de fixation c.i. (jeu x 6)	Printed circuit fixing spacer (set x 6)	Abstandhalter Befestigung Platine (6-er Satz)
86	1	0D5518	Support composant de c.i.	Printed circuit component support	Halterung Bauteil Platine
87	1	0D5679	Carte de puissance 2 vitesses	2-speed power card	Leistungskarte 2 Geschwindigkeiten
88	1	0D5544	Cordon d'alimentation tri équipé	Three-phase power supply lead assembly	Stromkabel Drehstrom ausgestattet
89	1	0D1708	Collier CV9 (jeu x 10)	CV9 tie (set x 10)	Schelle CV9 (10-er Satz)
100	2	0D6755	Vis TC M4x20 (jeux10)	Screw TC M4x20 (set x 10)	Schraube TC M4x20 (10-er Satz)
	2	0D6441	Entretoise 4x10x10 (jeux10)	Spacer (set x 10)	Abstandsring 4x10x10 (10-er Satz)
	2	0D6756	Ecrou M4 (jeux10)	Nut HU M4 base (set x 10)	Mutter M4 gezahnt (10-er Satz)
S22		0D6439	Support PSA complet 2V	Complete PSA support 2sp	Halterung PSA komplett 2GS
S17		0D5529	Carte commande complète K45 2V	Complete K45 2-sp. control card	Steuerkarte komplett K45 2GS
		0D5530	Carte commande complète K55 2V	Complete K55 2-sp. control card	Steuerkarte komplett K55 2GS
		0D5531	Carte commande complète K70 2V	Complete K70 2-sp. control card	Steuerkarte komplett K70 2GS
S18		0D5532	Platine complète 2v K45/K55/K70	Complete 2-sp. K45/K55/K70 circuit board	Platine komplett 2GS K45/K55/K7

N° N. Ref	Qté Qty	Cod Código Kod	Designazione	Descripción	Beskrivning
19	1	0D5429	Corpo	Cuerpo	Huvuddel
49	1	0D5515	Supporto scheda di comando	Soporte tarjeta de mando	Stöd drivkort
51	2	0D2918	Vite PTWN 1442 K30/8 (set x 10)	Tornillo PTWN 1442 K30/8 (juego x 10)	Skruv PTWN 1442 K30/8 (sats x 10)
53	2	0D5517	Supporto rilevatore	Soporte detector	Stöd detektor
54	3	0D6754	Vite M4x12 (set x 10)	Tornillo M4x12 (juego x 10)	Skruv M4x12 (sats x 10)
55	2	0D6626	Rilevatore di prossimità	Detector de proximidad	Lägesdetektor
79	1	0D7087	Piastra pannello comandi K45 2 V	Placa panel de mando K45 2 V	Platta, kontrollpanel K45 2 V
	1	0D7089	Piastra pannello comandi K55 2 V	Placa panel de mando K55 2 V	Platta, kontrollpanel K55 2 V
	1	0D7091	Piastra pannello comandi K70 2 V	Placa panel de mando K70 2 V	Platta, kontrollpanel K70 2 V
80	1	0D5600	Scheda di comando 2 velocità	Tarjeta de mando 2 velocidades	Drivkort 2 hastigheter
81	1	0H1034	Condensatore di arresto 200 mf	Condensador de frenado 200 mf	Bromskondensator 200 mf
82	1	0D3429	Vite lamiera M4x8 (set x 10)	Tornillo chapa M4x8 (juego x 10)	Gångpressande skruv M4x8 (sats x 10)
83	1	0D6438	Lira	Soporte lira	Lyra
84	2	0D6708	Vite taptite M6x16 (set x 10)	Tornillo taptite M6x16 (juego x10)	Skruv M6x16 (sats x 10)
85	6	0D2848	Distanziatore di fissaggio c.i. (set x 6)	Distanciador de fijación c.i. (juego x 6)	Distansstycke montering t.k. (sats x 6)
86	1	0D5518	Supporto componente di c.i.	Soporte componente de c.i.	Stöd komponent i t.k.
87	1	0D5679	Scheda di potenza 2 velocità	Tarjeta de potencia 2 velocidades	Effektkort 2 hastigheter
88	1	0D5544	Cavo di alimentazione tri in dotazione	Cable de alimentación tri equipado	Utrustad elsladd, trefasig
89	1	0D1708	Fascetta CV9 (set x 10)	Abrazadera CV9 (juego x 10)	Klämna CV9 (sats x 10)
100	2	0D6755	Vite TC M4x20 (gioco x 10)	Tornillo TC M4x20 (juego x10)	Skruv TC M4x20 (sats x 10)
	2	0D6441	Distanziatore 4x10x10 (set x 10)	Distanciador 4x10x10 (juego x 10)	Tvärstång 4x10x10 (sats x 10)
	2	0D6756	Dado HU M4 base dentata (jeu x 10)	Tuerca HU M4 base dentada (juego x 10)	Mutter HU M4 med räfflad fläns (sats x 10)
S22		0D6439	Supporto PSA completo 2V	Soporte PSA completo 2V	Komplett stöd, PSA 2V
S17		0D5529	Scheda di comando completa K45 2V	Tarjeta mando completa K45 2V	Komplett drivkort K45 2V
		0D5530	Scheda di comando completa K55 2V	Tarjeta mando completa K55 2V	Komplett drivkort K55 2V
		0D5531	Scheda di comando completa K70 2V	Tarjeta mando completa K70 2V	Komplett drivkort K70 2V
S18		0D5532	Piastra completa 2v K45/K55/K70	Platina completa 2v K45/K55/K70	Komplett platin 2v K45/K55/K70

**Vue éclatée platine 2 vitesses triphasé / 2-speed three-phase circuit board exploded view / Explosionszeichnung Platine 2 Geschwindigkeiten Drehs-trom / Esploso piastra 2 velocità trifase / Despiece platina 2 velocidades trifásica / Sprängskiss platin 2 hastigheter, trefasig \_\_\_\_\_**

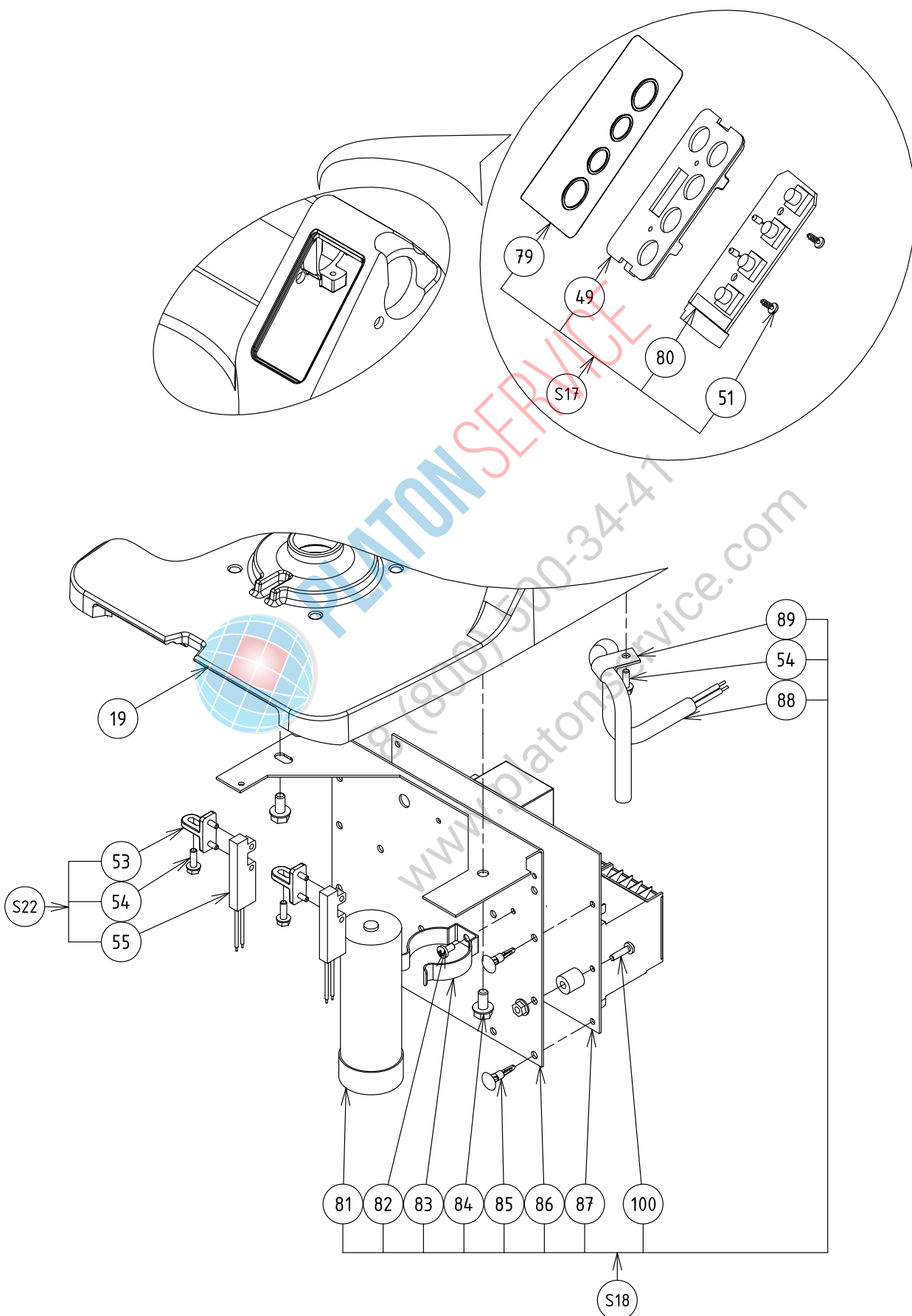

# Nomenclature platine variateur de vitesse / Parts list Variable speed unit circuit board / Stückliste Platine Regelantrieb / Nomenclatura piastra variatore di velocità / Nomenclatura platina variador de velocidad / Specification platin hastighetsvariator

Rep. Item Pos.	Qté Qty Mge	Code Part N° Teile-Nr	Désignation	Description	Bezeichnung
19	1	OD5429	Corps	Body	Gehäuseoberteil
49	1	OD5515	Support carte de commande	Control card support	Halterung Steuerkarte
51	2	OD2918	Vis PTWN 1442 K30/8 (jeu x 10)	1442 K30/8 PTWN screw (set x 10)	Schraube PTWN 1442 K30/8 (10-er Satz)
53	2	OD5517	Support détecteur	Detector support	Sensorhalterung
54	7	OD6754	Vis M4x12 (jeu x 10)	M4x12 screw (set x 10)	Schraube M4x12 (10-er Satz)
55	2	OD6626	Détecteur de proximité	Proximity detector	Näherungsschalter
90	1	OD7088	Plaque tableau de bord K45 V V	K45 Var. Sp. control panel plate	Platte Bedienerfeld K45 GR
	1	OD7090	Plaque tableau de bord K55 V V	K55 Var. Sp. control panel plate	Platte Bedienerfeld K55 GR
	1	OD7092	Plaque tableau de bord K70 V V	K70 Var. Sp. control panel plate	Platte Bedienerfeld K70 GR
91	1	OD5546	Carte de commande P/M/A/+/-	Power/On/off/+/- control card	Steuerkarte P/E/A/+/-
92	1	voir S20	Variateur	Variable speed unit	Regelantrieb
93	2	OD0551	Vis taptite M6x12 (jeu x 10)	M6x12 Taptite screw (set x 10)	Taptite Schraube M6x12 (10-er Satz)
94	1	voir S20	Support variateur	Variable speed unit support	Halterung Regelantrieb
95	1	OD5545	Cordon d'alimentation mono équipé	Single phase power supply lead assembly	Stromkabel Wechselstrom ausgestattet
96	1	OD6040	Collier CV8 (jeu x 10)	CV8 tie (set x 10)	Schelle CV8 (10-er Satz)
S19	1	OD5749	Carte de commande K45 V V complète	Complete K45 Var. Sp. control card	Steuerkarte K45 GR komplett
	1	OD5750	Carte de commande K55 V V complète	Complete K55 Var. Sp. control card	Steuerkarte K55 GR komplett
	1	OD5751	Carte de commande K70 V V complète	Complete K70 Var. Sp. control card	Steuerkarte K70 GR komplett
S20	1	OD5607	Support variateur complet	Complete variable speed unit support	Halterung Regelantrieb komplett
S25	1	OD5543	Support PSA complet (porte-languettes)	Complete PSA support (lug holder)	Halterung PSA complet (Laschenhalter)
S26	1	OD5522	Support PSA complet	Complete PSA support	Halterung PSA complet

N° N. Ref	Qtà Cad Kvant	Cod Código Kod	Designazione	Descripción	Beskrivning
19	1	OD5429	Corpo	Cuerpo	Huvuddel
49	1	OD5515	Supporto scheda di comando	Soporte tarjeta de mando	Stöd drivkort
51	2	OD2918	Vite PTWN 1442 K30/8 (set x 10)	Tornillo PTWN 1442 K30/8 (juego x 10)	Skruv PTWN 1442 K30/8 (sats x 10)
53	2	OD5517	Supporto rilevatore	Soporte detector	Stöd detektor
54	7	OD6754	Vite M4x12 (set x 10)	Tornillo M4x12 (juego x 10)	Skruv M4x12 (sats x 10)
55	2	OD6626	Rilevatore di prossimità	Detector de proximidad	Lägesdetektor
90	1	OD7088	Piastra pannello comandi K45 V V	Placa panel de mando K45 V V	Platta kontrollpanel K45 V V
	1	OD7090	Piastra pannello comandi K55 V V	Placa panel de mando K55 V V	Platta kontrollpanel K55 V V
	1	OD7092	Piastra pannello comandi K70 V V	Placa panel de mando K70 V V	Platta kontrollpanel K70 V V
91	1	OD5546	Scheda di comando P/M/A/+/-	Tarjeta de mando P/M/A/+/-	Drivkort P/M/A/+/-
92	1	voir S20	Variatore	Variador	Variator
93	2	OD0551	Vite taptite M6x12 (set x 10)	Tornillo taptite M6x12 (juego x10)	Skruv M6x12 (sats x 10)
94	1	voir S20	Supporto variatore	Soporte variador	Stöd variatr
95	1	OD5545	Cavo di alimentazione mono in dotazione	Cable de alimentación mono equipado	Utrustad elsadd, mono
96	1	OD6040	Fascetta CV8 (set x 10)	Abrazadera CV8 (juego x 10)	Klämna CV8 (sats x 10)
S19	1	OD5749	Scheda di comando K45 V V completa	Tarjeta de mando K45 V V completa	Komplett drivkort K45 V V
	1	OD5750	Scheda di comando K55 V V completa	Tarjeta de mando K55 V V completa	Komplett drivkort K55 V V
	1	OD5751	Scheda di comando K70 V V completa	Tarjeta de mando K70 V V completa	Komplett drivkort K70 V V
S20	1	OD5607	Supporto variatore completo	Soporte variador completo	Komplett stöd, variator
S25	1	OD5543	Supporto PSA completo (portalinguette)	Soporte PSA completo (portalingüetas)	Komplett stöd, PSA (flikhållare)
S26	1	OD5522	Supporto PSA completo	Soporte PSA completo	Komplett stöd, PSA

**Vue éclatée platine variateur de vitesse / Variable speed unit circuit board exploded view / Explosionszeichnung Platine Regelantrieb / Esploso piastra variatore di velocità / Despiece platina variador de velocidad / Sprängskiss platin hastighetsvariator**

